

Your Guide to Cost Reduction through Pneumatics Automation

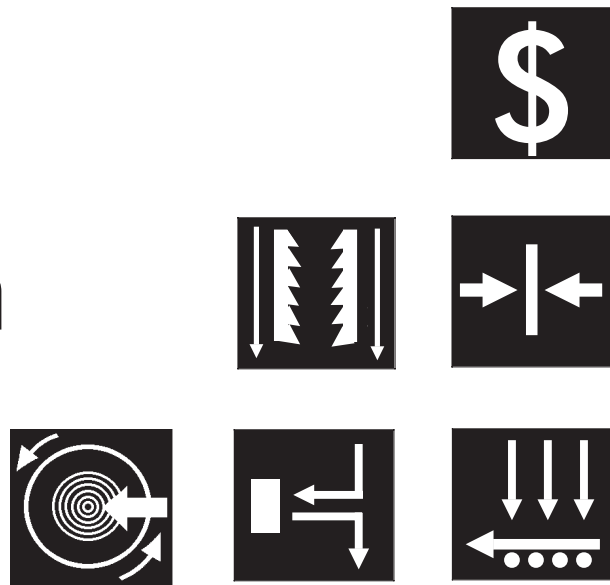

The members of the National Fluid Power Association (NFPA) have prepared this handbook as an introduction to pneumatics automation. It is designed to show you — in straightforward terms — how pneumatics can reduce your manufacturing costs with a minimum of investment and complexity.

The applications and components described here are representative — pneumatics automation can be effectively utilized in countless automation processes, and pneumatic components are available in many different sizes and configurations. NFPA's manufacturers invite you to contact them for additional information as you take the next steps toward automating with pneumatics.

The applications and components described or pictured here are illustrative only. Depiction or description of any product or component does not constitute, indicate or imply a recommendation or endorsement of any sort with respect to any system, products or components. Information and illustrations contained in this booklet do not constitute or indicate a warranty, express or implied, including but not limited to a warranty or representation as to quality, merchantability, or fitness for a particular use or purpose of any system, product or component.



Copyright © 1990 by the National Fluid Power Association. All rights reserved.

ISBN 0-942220-23-4



Pneumatics Automation at Work – Broaching

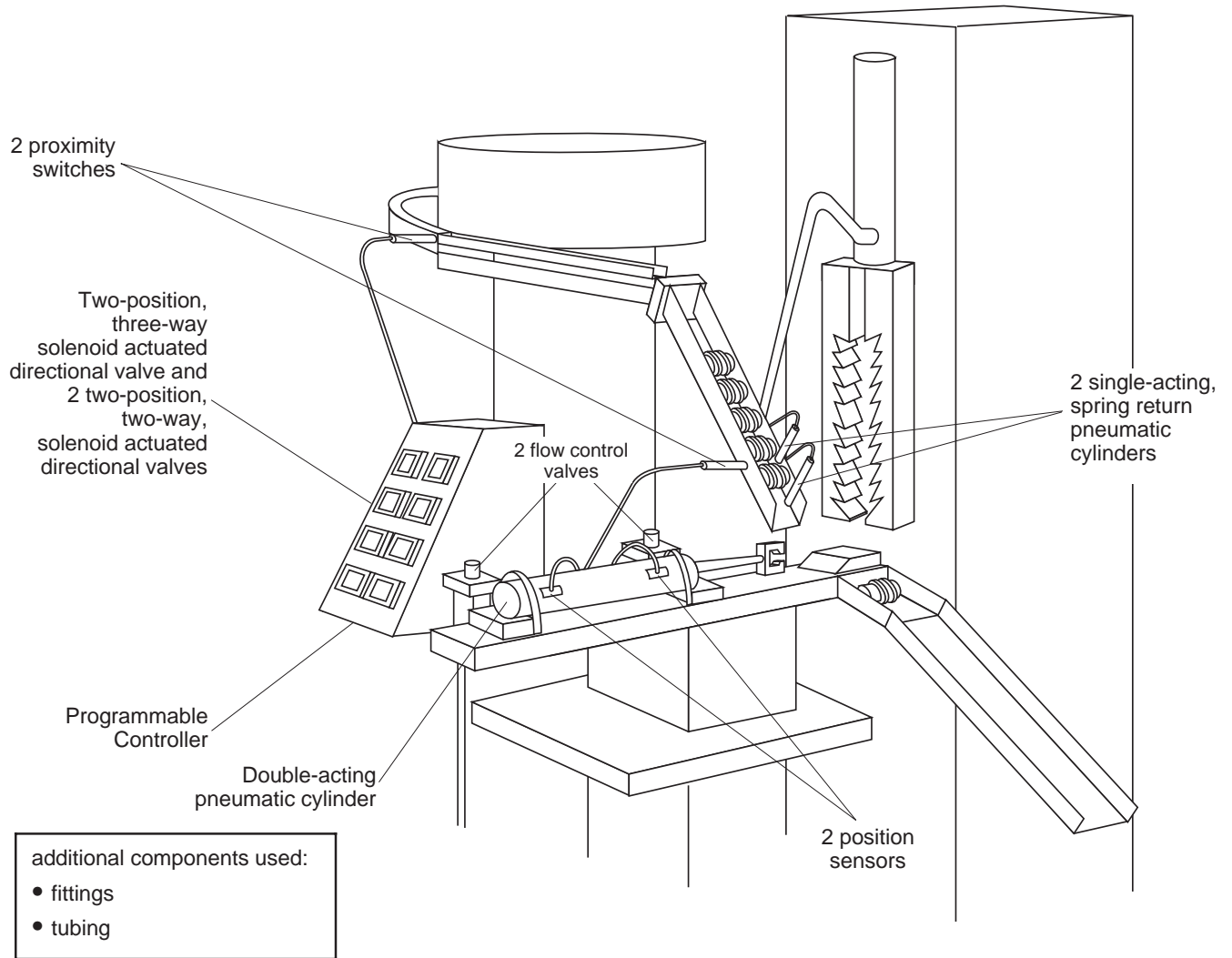

The Problem and Its Solution

A manufacturer made an aluminum fitting as part of a subassembly. It used a horizontal mill to cut four flats into the cylindrical fitting. This process required using a fixture to hold a group of these fittings in line on the bed of a horizontal milling machine. The fittings were moved past a milling cutter in one direction to make flats on one side, and then were turned over for a second milling cut. When the process was completed, the fixture was filled with a new set of fittings to be processed. The machining required an operator to be in attendance at all times.

To increase output from this operation, it was decided to employ a vertical surface broach which would automatically be fed the fittings. The broach used four sets of saw-like teeth to cut all four flats simultaneously. In addition, a vibratory feeder bowl was attached to the broach which allowed an operator to fill the bowl with fittings and then leave the machine in operation to perform another function.

Broaching

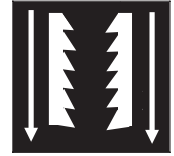

The Design and Construction Process

- 1) A standard vertical broach was outfitted with a single-acting hydraulic ram to drive the broaching jaws.
- 2) A vibratory feeder bowl was mounted to the broach. It included a gravity-fed chute which presented the cylindrical fittings to a mechanical gripper. Proximity sensors were attached at each end of the chute to confirm that fittings were moving through. Two small pneumatic cylinders were placed in line as stops at the end of the chute. This was done in order to present a single fitting to the mechanical gripper. This procedure was accomplished by extending one cylinder into the chute in front of the second to last fitting, halting this fitting, as a second cylinder was retracted to let the last fitting through.
- 3) The mechanical gripper was attached to a pneumatic cylinder which moved the fitting into the broach. A fixture was placed underneath the lower gripper jaw so that as it was moved by the cylinder, it would hold the fitting tightly against the upper gripper jaw. Two reed-type position sensors were placed at both ends of the pneumatic cylinder to confirm when the gripper was in either the loading or holding (forward or back) position. Flow controls were used to adjust the rate of the pneumatic cylinder's motion.
- 4) An outlet shoot was attached to catch the broached fittings as they slipped from the loosened gripper jaws during the gripper's retraction stroke. Mechanical trip switches at each end of the broach's stroke signaled its readiness for, or completion of, its cut. A coolant spray, circulation pump and catch basin also were utilized, as were solenoid-actuated pneumatic and hydraulic directional valves to control the action of the pneumatic cylinders and the hydraulic ram.
- 5) A programmable controller sequenced the entire operation. It used the inputs from the proximity and position sensors and trip switches to determine when to signal the start of the next phase in the operation. Operation ceased when a sensor failed to signal the completion of a cylinder's stroke or found no fittings at either end of the supply chute. The controller was wired into an operator control panel.

Payback: Manual vs. Automated Processes*

Time Savings Per Unit

13 seconds (manual) - .5 seconds (automated) =
12.5 seconds

Labor Savings Per Month

.0035 hour (12.5 seconds) x \$10 per hour (average hourly rate) x 40,708 units per month = \$1,425

Number of Months to Payback Investment

\$20,000 component cost / \$1,425 monthly labor savings = 14.0

***NOTE:** Supplied figures for all applications in this guide are based upon 21 work days per month with one 7-hour shift operating and an average hourly rate including benefits but not including operating overhead. The component costs listed do not include the tooling or labor required to build the application. For an estimate of total application costs, double the total component cost. Final application costs will vary based upon individual labor costs, skill levels and final application design.

Components Used in Pneumatic Applications*:

Actuators	Hose
After Coolers	Manifolds
Air Compressors	Motors
Air Dryers	Mufflers
Air Line Lubricators	Regulators
Controls (electronic) and Software	Rotary Actuators
Cylinders	Seals
Filters	Shock Absorbers
Filters/Regulators	Slides
FRLs	Switches
Fittings	Tubing
Gauges	Vacuum Products
Grippers	Valves

***Click here to access the NFPA Fluid Power Product Locator, which includes information about and links to NFPA member companies.**